

KELOX

KMU440 KELOX-ULTRAX tee 32/20/32

71110FDF

Areas of application

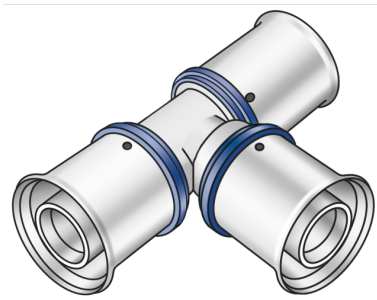

Press-fit tee equal or reduced, made of non-porous metallised brass, incl. support sleeves with O-rings and stainless steel press-fit sleeves, "leak before pressed"

Approvals:



KE KELIT GmbH

A 4020 Linz, Ignaz-Mayer-Straße 17, Austria, Europe

PHONE +43 (0) 50 779 E-MAIL office@kekelit.com

www.kekelit.com

Specifications

Article information

port 1	Pressmuffe
port 2	press sleeve
port 3	press sleeve
execution	T-piece
angle	90 °
press contour	U

Technical properties

maximum working pressure at 20 ° C	16 bar
------------------------------------	--------

Product information

VPE1	4,00 SA1
VPE2	40,00 KT1
weight	0,3180 KGM
text	KELOX-ULTRAX tee
INTRNR	74122000
main material group	KELOX
material group	KELOX-ULTRAX metal fittings
code	KMU440

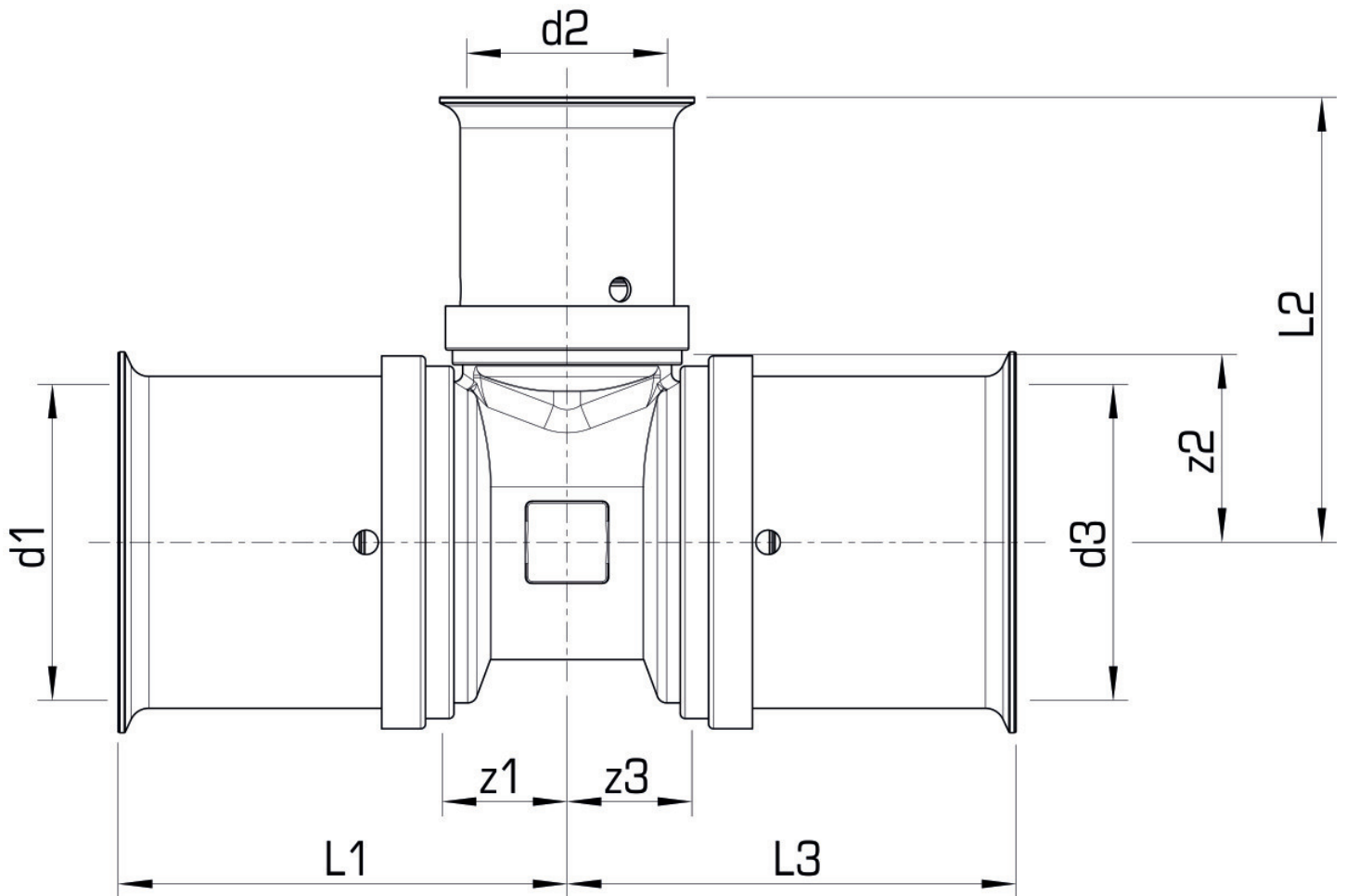

Art. No	label	d1 mm	d2 mm	d3 mm	L1 mm	L2 mm	L3 mm	z1 mm	z2 mm	z3 mm
71110FDF	32/20/32	32	20	32	46	46	46	13	20	13