

KELOX

KWW440 KELOX-WINDOW-W tee 25/20/25

72311EDE

Areas of application

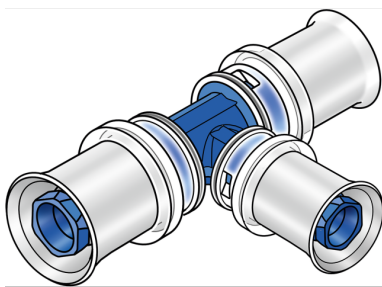

?Zeta value-optimised press-fit tee, equal or reduced, made from PPSU, including support sleeves with O-rings and stainless steel press-fit sleeves "leak before pressed", audible leakage signal at air-pressure testing

Approvals:



Specifications

Article information

port 1	Pressmuffe
port 2	Pressmuffe
port 3	Pressmuffe
press contour	U

Technical properties

maximum working pressure at 20 ° C	16 bar
------------------------------------	--------

Product information

VPE1	5,00 SA1
VPE2	25,00 KT1
VPE3	1800,00 PAL
weight	0,0740 KGM
text	KELOX-WINDOWX-W tee
INTRNR	74122000
main material group	KELOX
code	KWW440

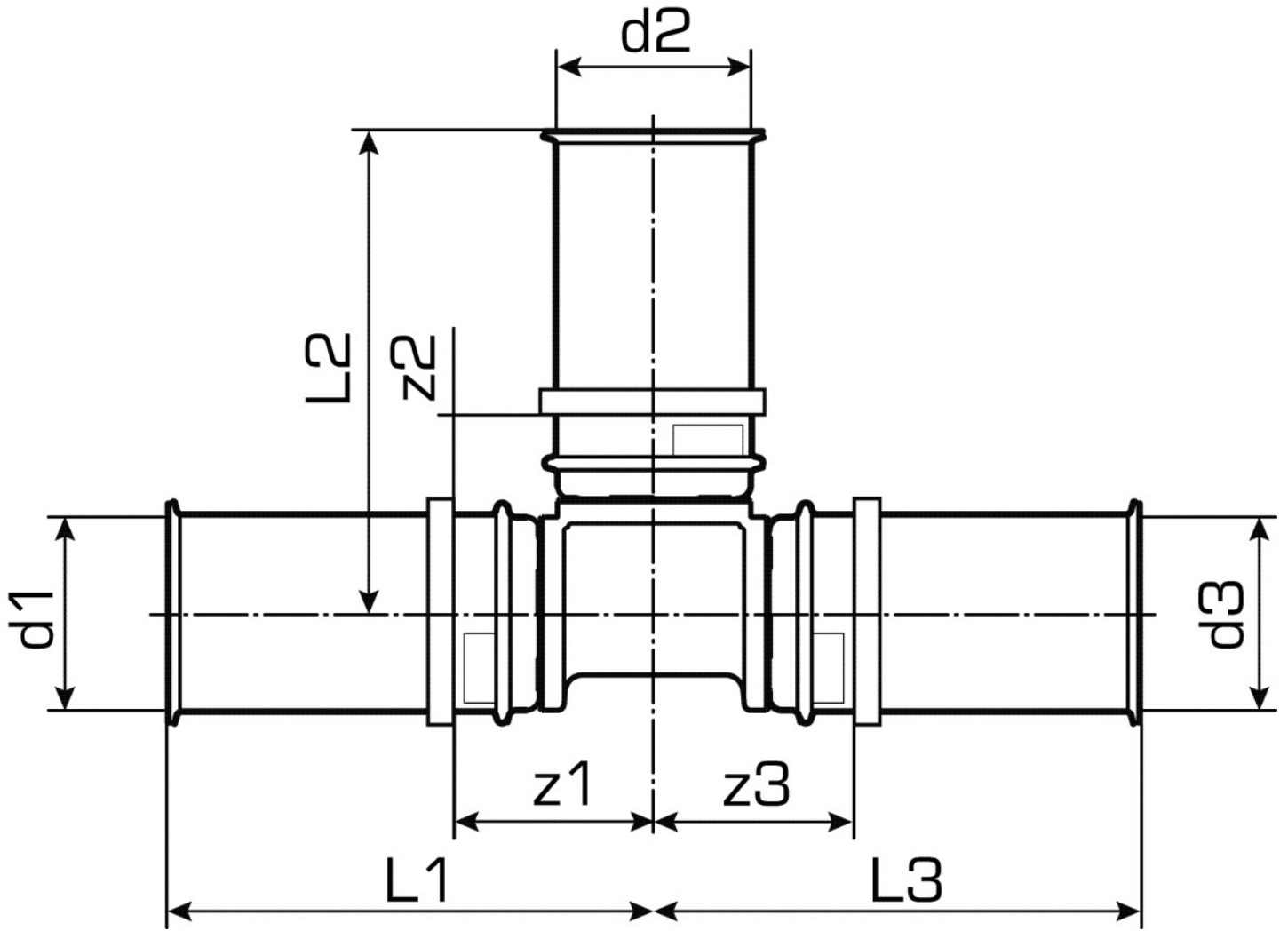

Art. No	label	d1 mm	d2 mm	d3 mm	L1 mm	L2 mm	L3 mm	z1 mm	z2 mm	z3 mm
72311EDe	25/20/25	25	20	25	50	48	50	20	22	20