

PHONEX

PHONEX AS-PLUS parallel branch

14794KK0

Areas of application

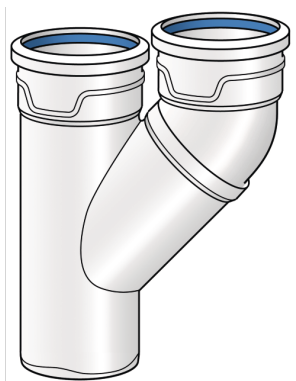

PP mineral-reinforced sound-deadening moulded part; with moulded push-in sleeves, patented lip seal with integrated lubricant and hexagonal chamfering to reduce insertion forces

Specifications

Product information

text

PHONEX AS-PLUS parallel branch

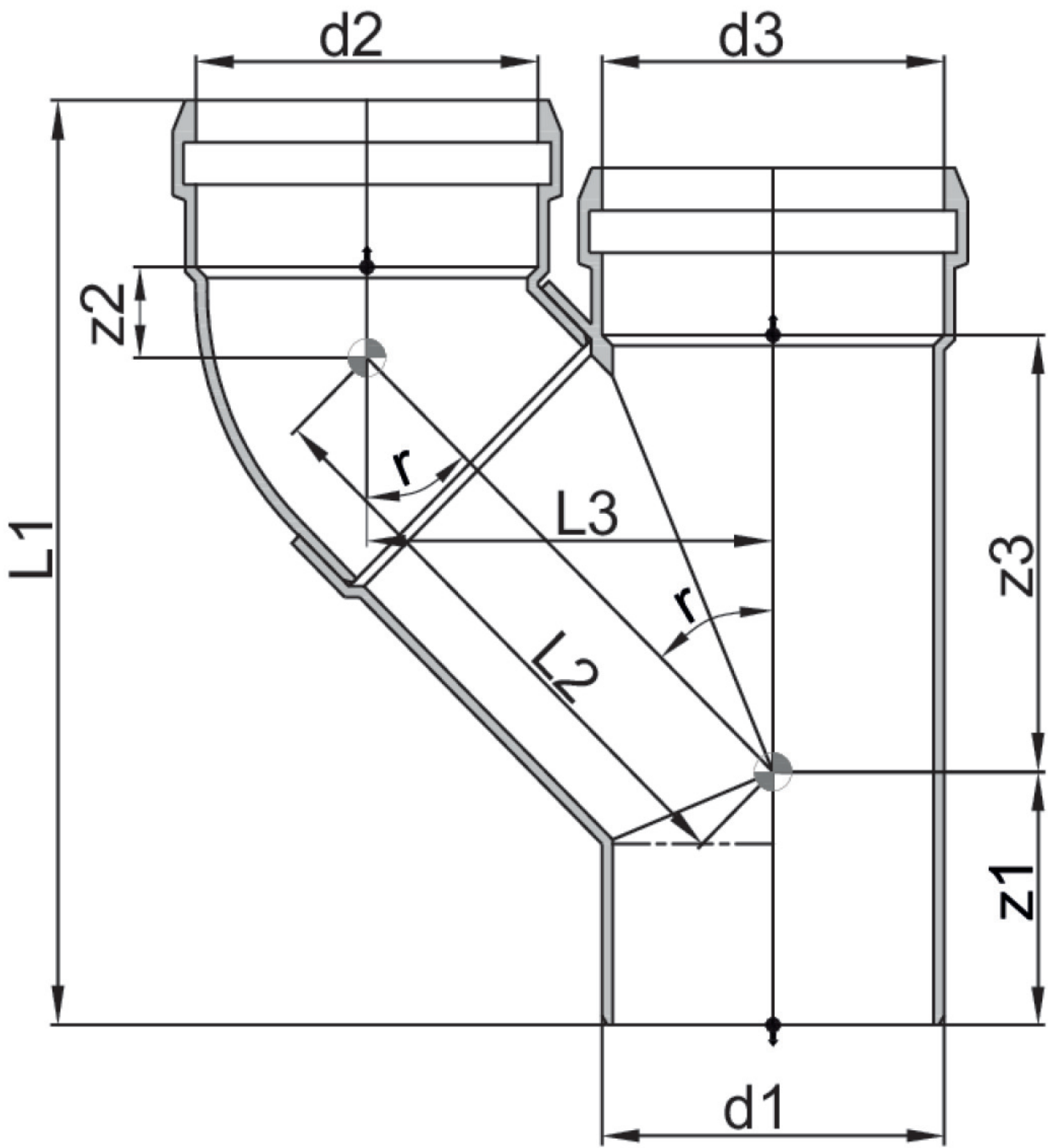

Art. No

14794KK0



KE KELIT GmbH

A 4020 Linz, Ignaz-Mayer-Straße 17, Austria, Europe

PHONE +43 (0) 50 779 **E-MAIL** office@kekelit.com

www.kekelit.com